

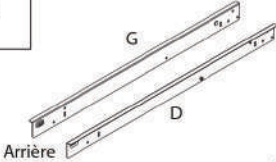

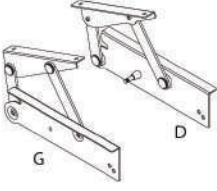

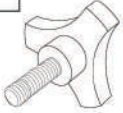





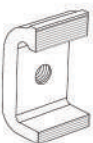





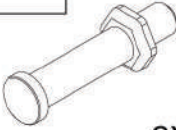
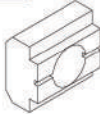
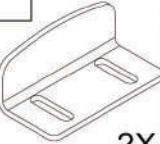
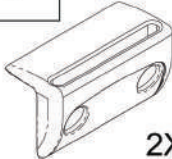



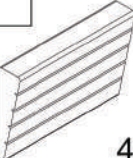
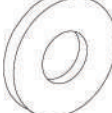

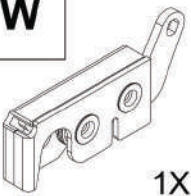
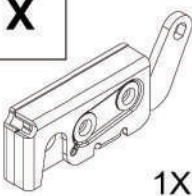

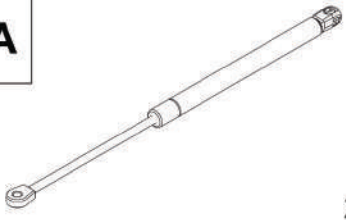
UpStoneEvolve

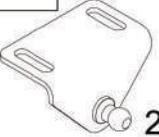
NOTICE DE MONTAGE - KIT K408

MB CLASSE-X 2016+ SANS ROLL BAR

A  1X	B  Arrière 1X	C  1X	D  2X		
E  2X	F  4X	G  M8x25mm 4X	H  M8 x16 Rondelle inox 6X	I  2X	J  Ecrou Nyloc M8 4X
K  Rondelle à ressort inox M8 2X	L  2X	M  2X	N  2X	O  2X	P  M6x18 16X
Q  M6x13mm Zinc 12X	R  M6x10mm 12X	S  4X	T  4X	U  M10x24mm 4X	V  M8 x16 Rondelle zinc 8X
W  Côté droit 1X	X  Côté gauche 1X	Y  M5 Boulon pour câbles, rondelle et écrou borgne 2X	Z  2X	AA  2X	
AB  1X	AC  2X	<p>Remarque : Il est préférable d'installer le tonneau cover avec un bac de benne SANS REBORDS TOUT MONTAGE AVEC BAC DE BENNE AVEC REBORDS N'EST PAS RECOMMANDE !</p> <p>Outils nécessaires :</p>        <p>OPTIONNEL</p>			
AD  4X					

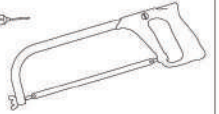
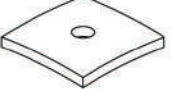
Kit de montage	Article	Revision	Date	Page
K408	Tonneau cover UpStone	1	26.02.2018	1 sur 7

1

Démontez le porte-échelle

Remarque : Il est préférable d'installer le tonneau cover avec un bac de benne SANS REBORDS

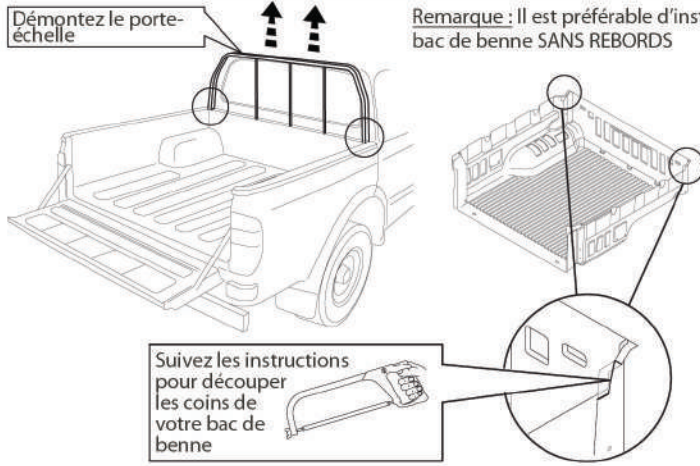

Suivez les instructions pour découper les coins de votre bac de benne

2

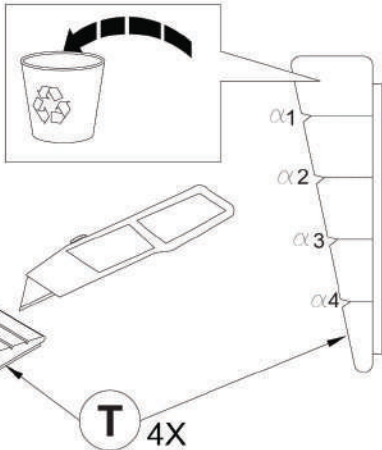

Modèle véhicule	α
Mercedes Classe-X Double cab	2

T 4X

3

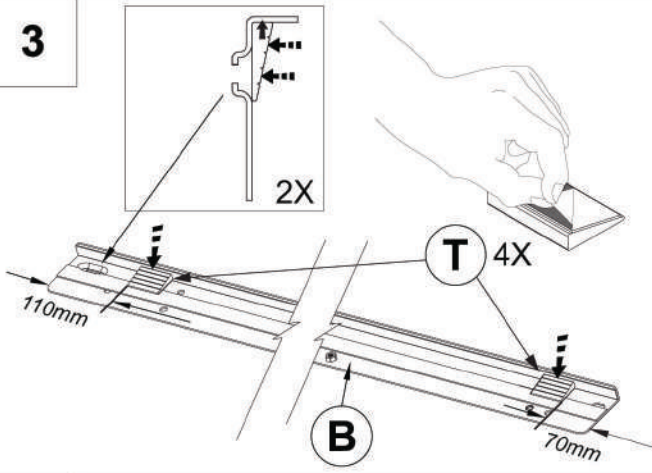

4

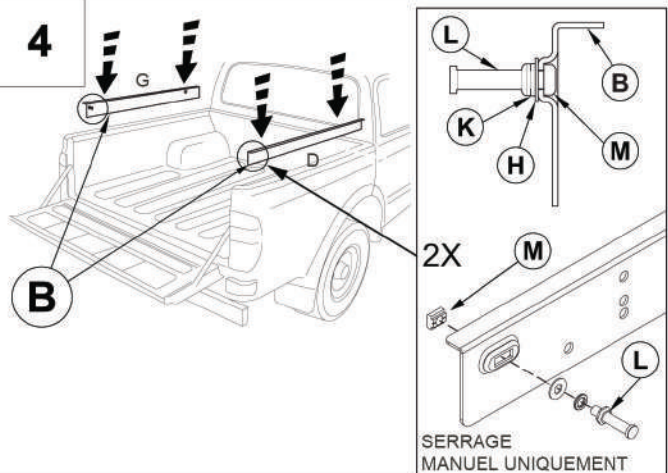

SERRAGE MANUEL UNIQUEMENT

5

A l'avant des rails, placez le crochet sur la face arrière du rail - voir tableau pour les mesures

Modèle véhicule	β	δ	φ
Mercedes Classe-X Double cab	80mm	1	7

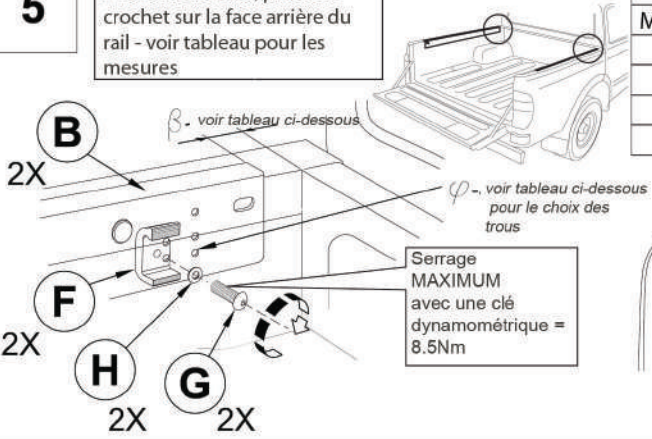

Serrage MAXIMUM avec une clé dynamométrique = 8.5Nm

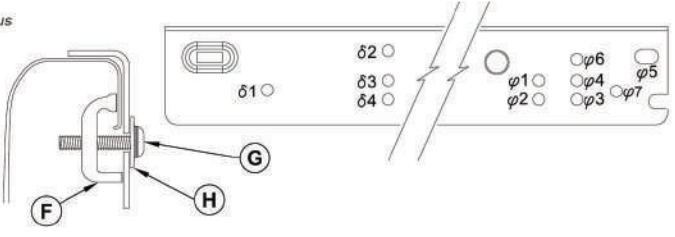

6

⌀ - Voir tableau page 2 pour le choix des trous

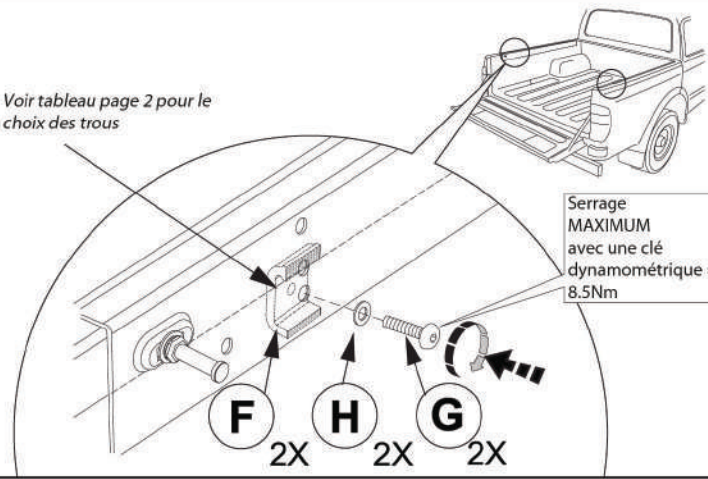

Serrage
MAXIMUM
avec une clé
dynamométrique =
8.5Nm

F 2X H 2X G 2X

7

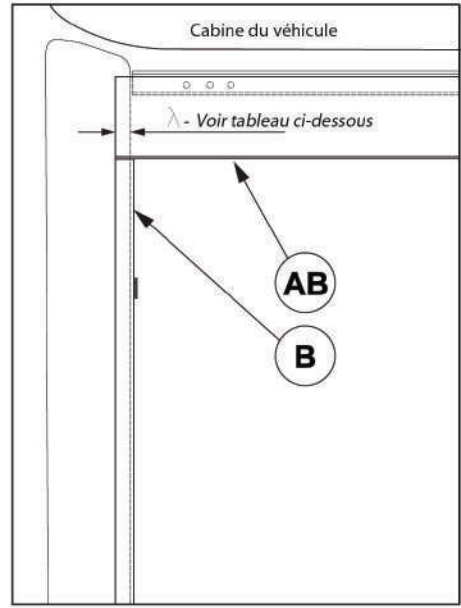
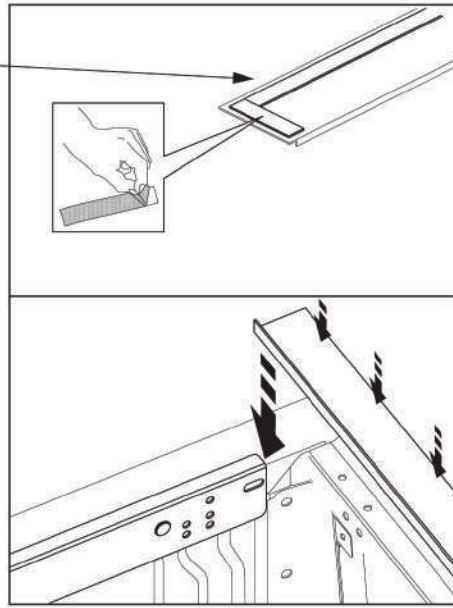
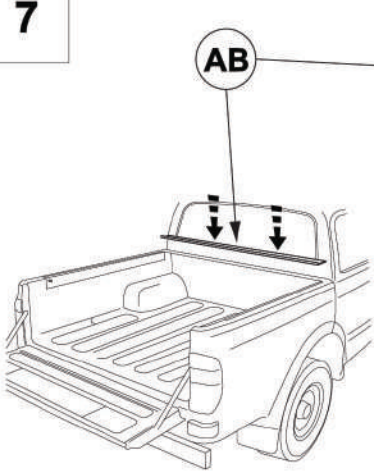

Cabine du véhicule

λ - Voir tableau ci-dessous

Vehicle Model	λ
Mercedes Classe-X Double cab	25mm

 Il est préférable de ne pas installer les rails en dessous de 15°C. Appliquez une pression sur la pièce. L'adhésif est activé par la pression.

8

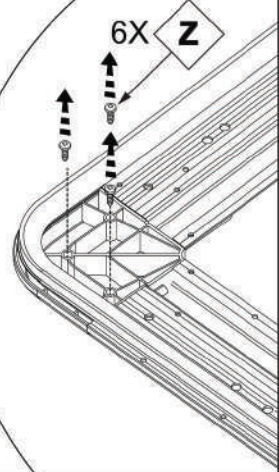
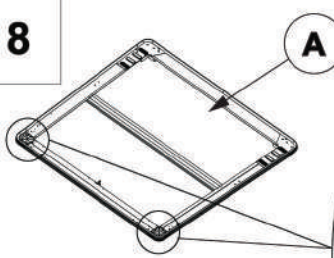

9

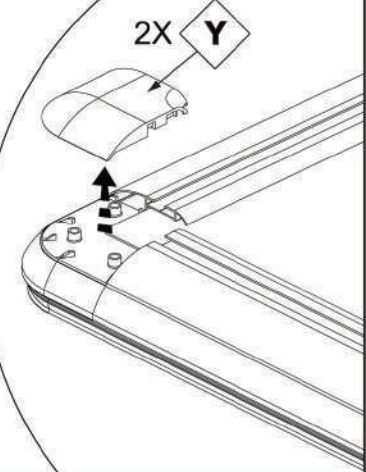
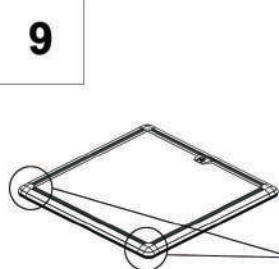

Kit de montage	Article	Revision	Date	Page
K408	Tonneau cover UpStone	1	26.02.2018	3 sur 7

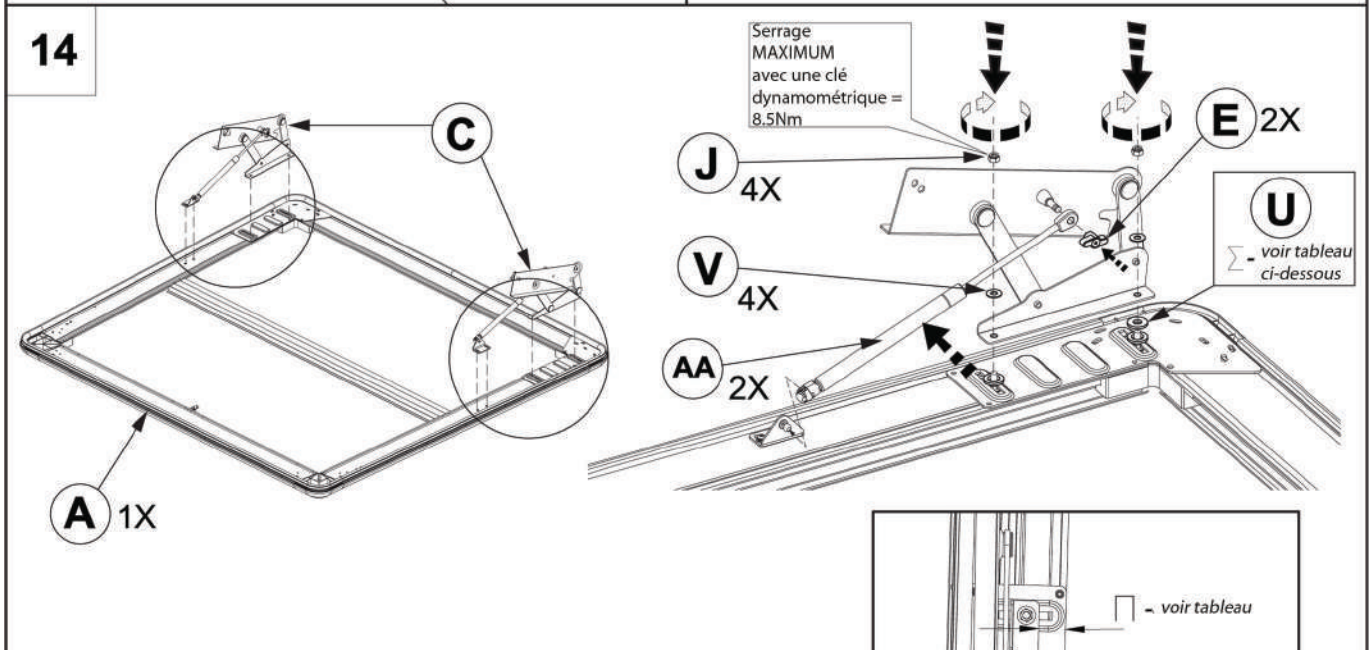
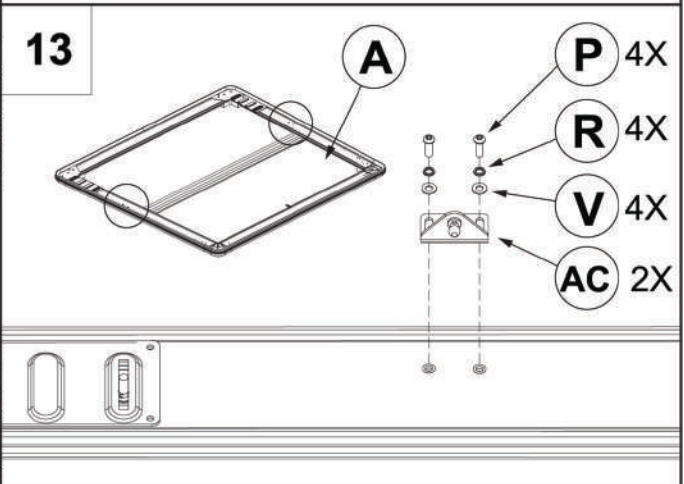
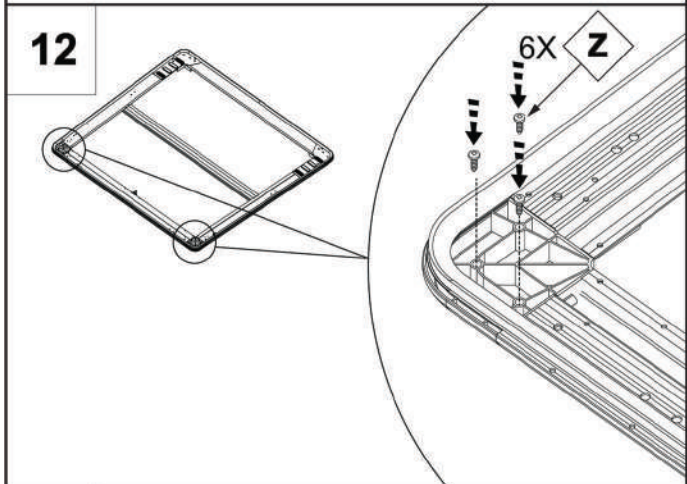
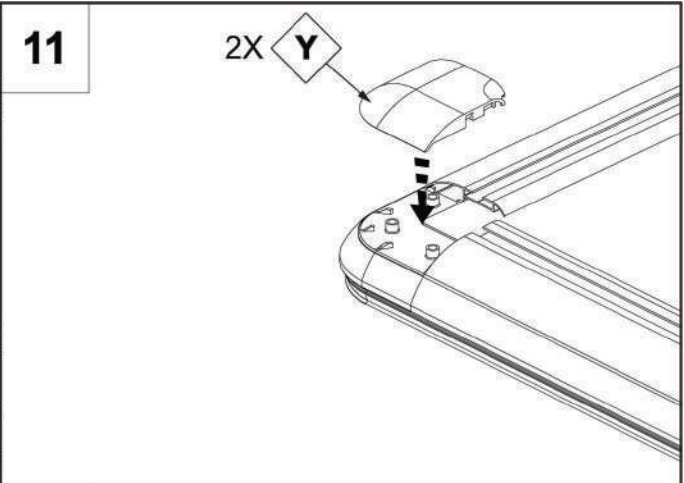
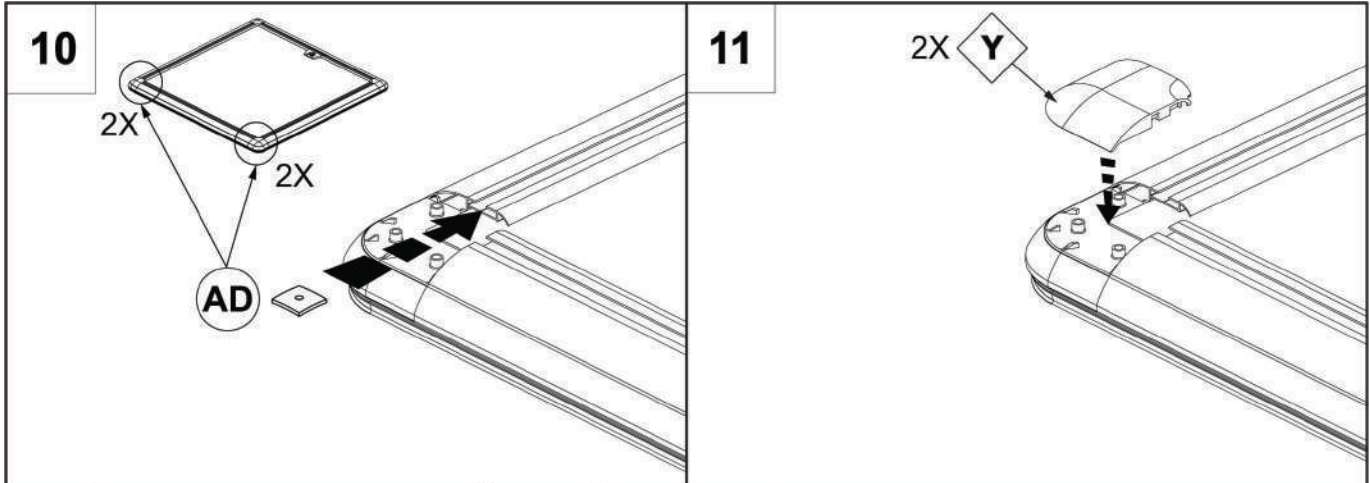

Vehicle Model	Π	Θ	Σ
Mercedes Classe-X Double cab	16.5mm	16.5mm	-

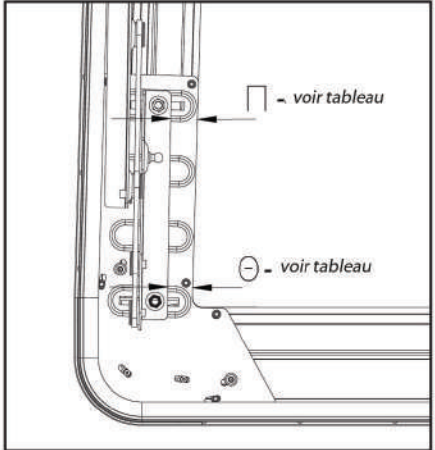

15

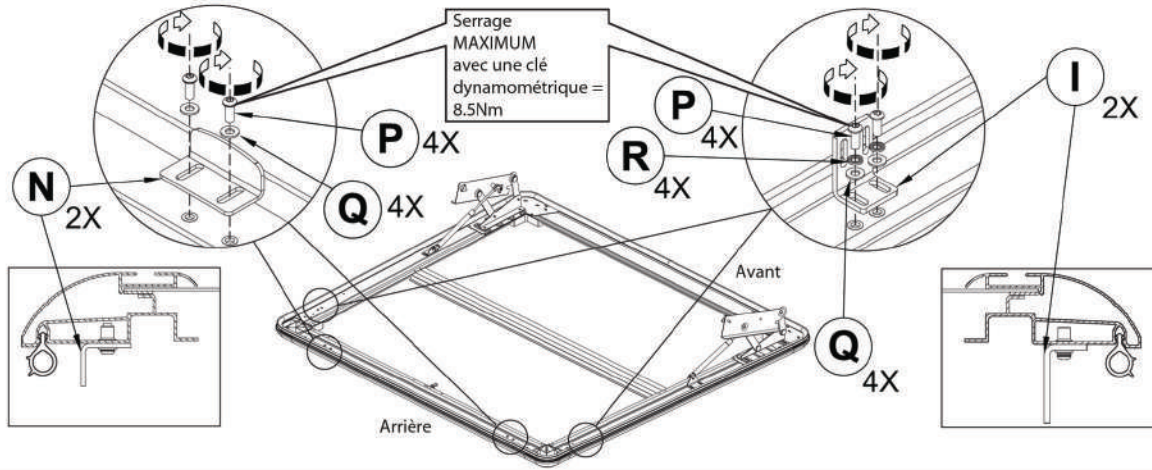

16

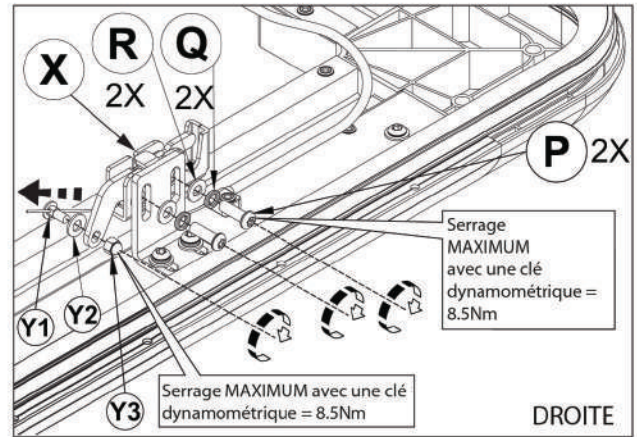
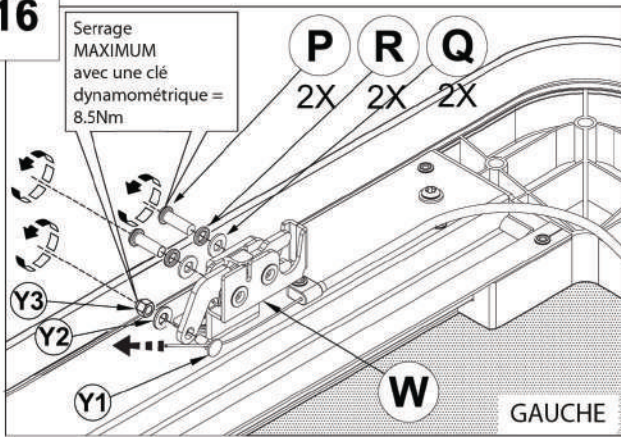

17

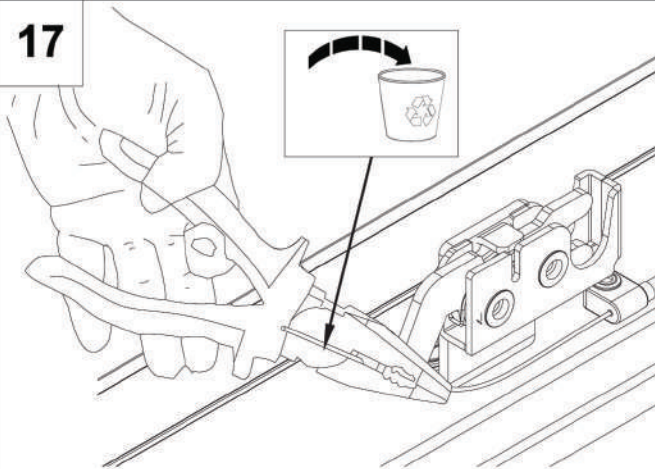

18

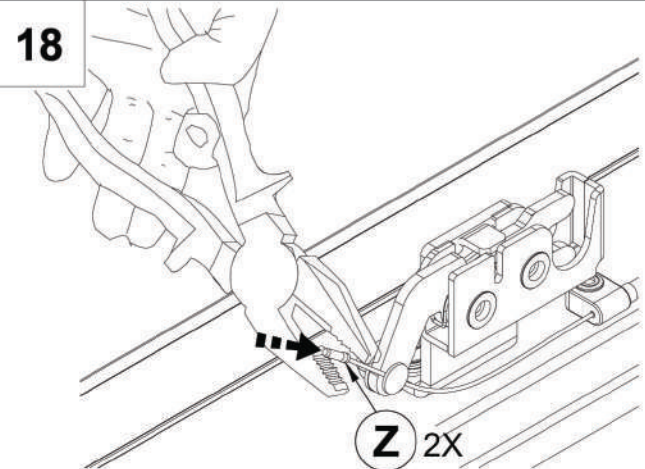

19

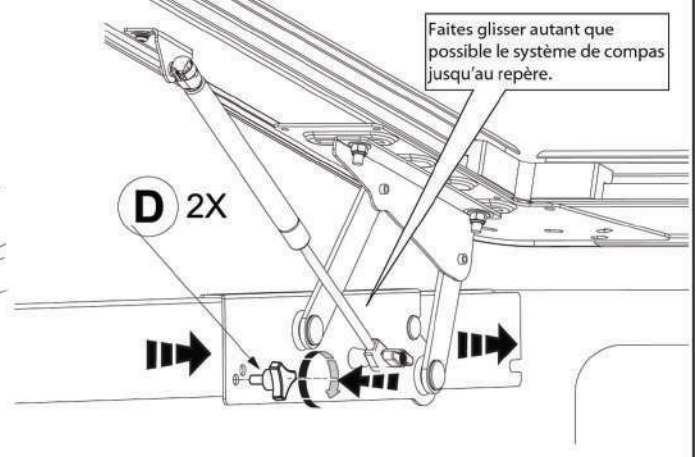
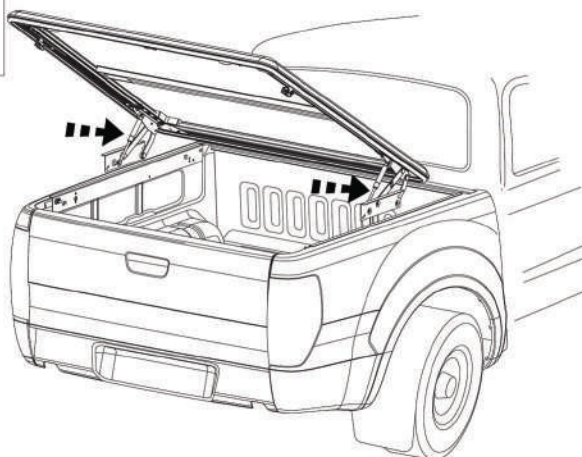

Notice de montage	Article	Revision	Date	Page
K408	Tonneau cover UpStone	1	26.02.2018	5 sur 7

20

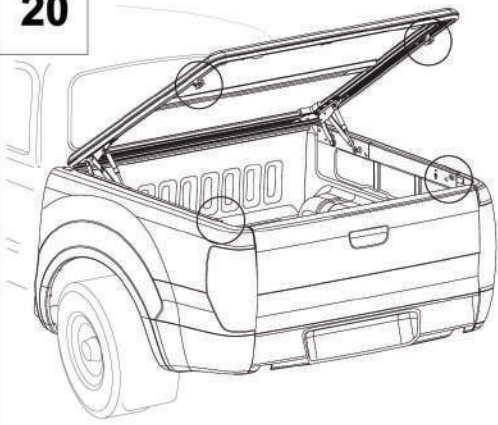

Serrage MAXIMUM avec une clé dynamométrique =8.5Nm

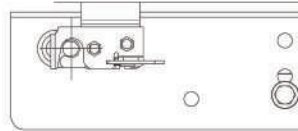
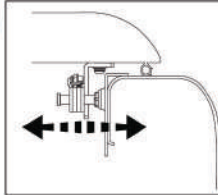
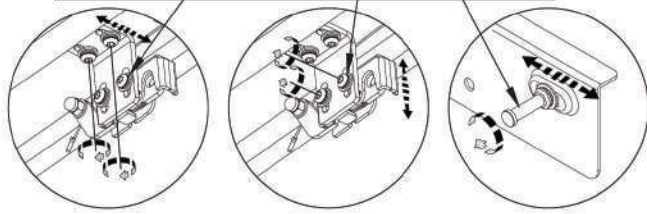

Aligner les gaches (femelle et mâle) de façon à ce que les gaches s'alignent.
Ajuster la tension du câble.
Important : vérifier l'étanchéité du cover (joint).

21

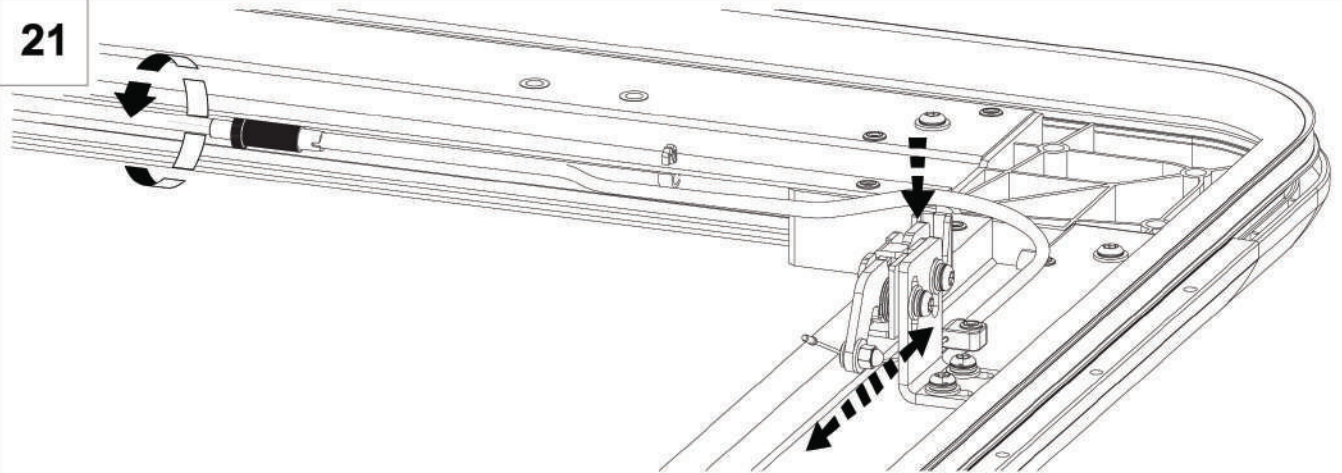

22

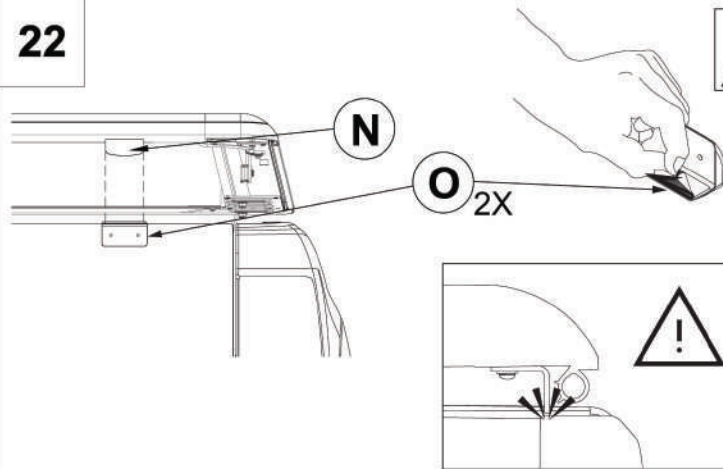

Il est préférable de ne pas installer les rails en dessous de 15°C.
Appliquez une pression sur la pièce. L'adhésif est activé par la pression.

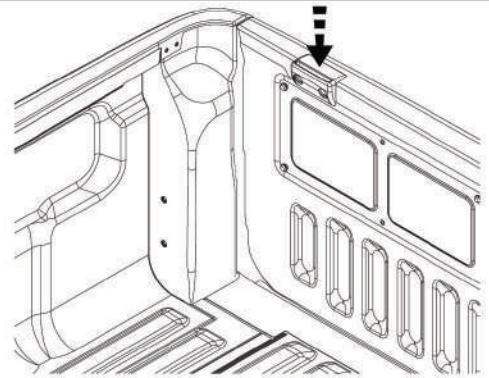

23

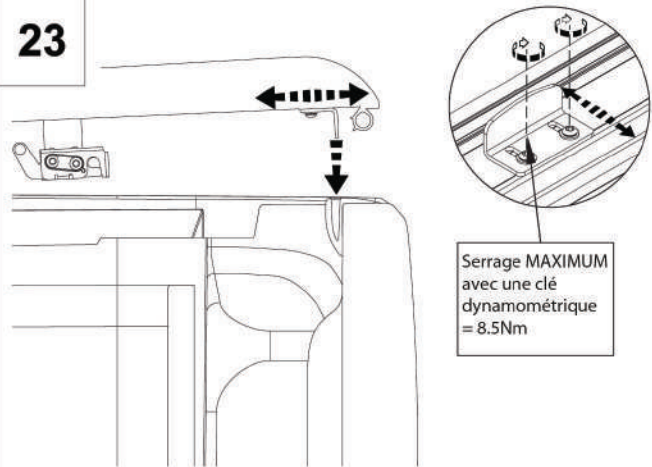

24

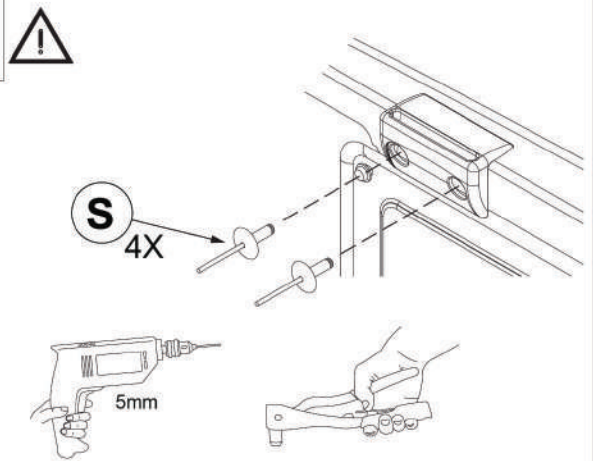

Kit de montage	Article	Revision	Date	Page
K408	Tonneau cover UpStone	1	26.02.2018	6 sur 7

25



S'assurer que le vérin est parfaitement droit.

Ajuster le point d'attache sur la benne si nécessaire.

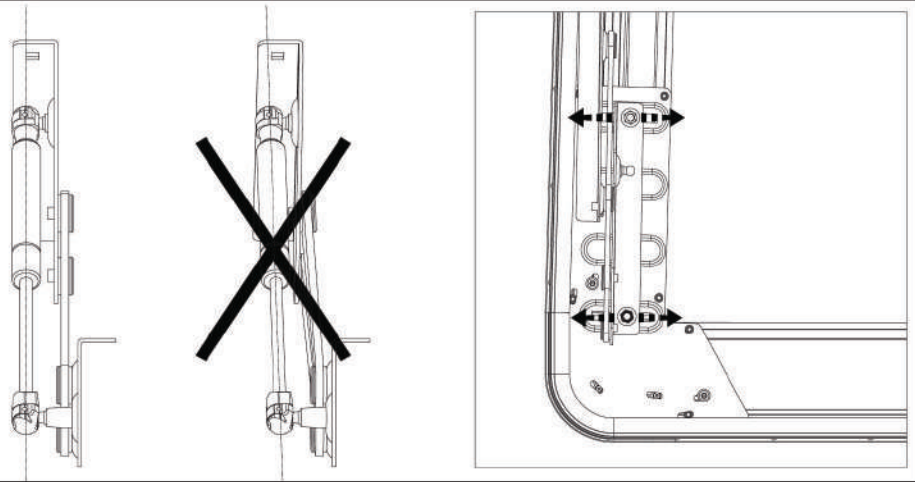

26

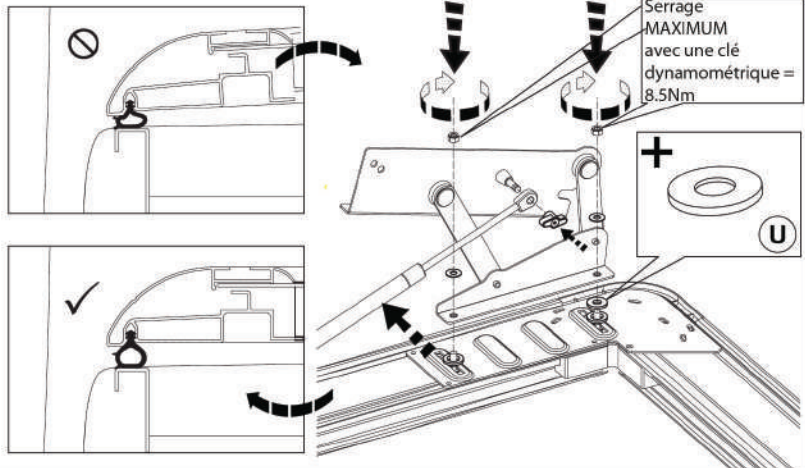
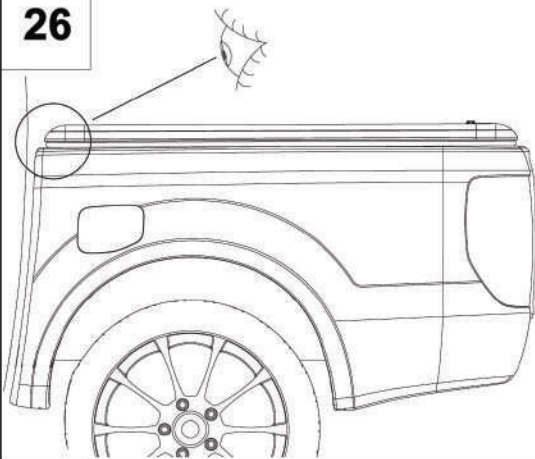

27

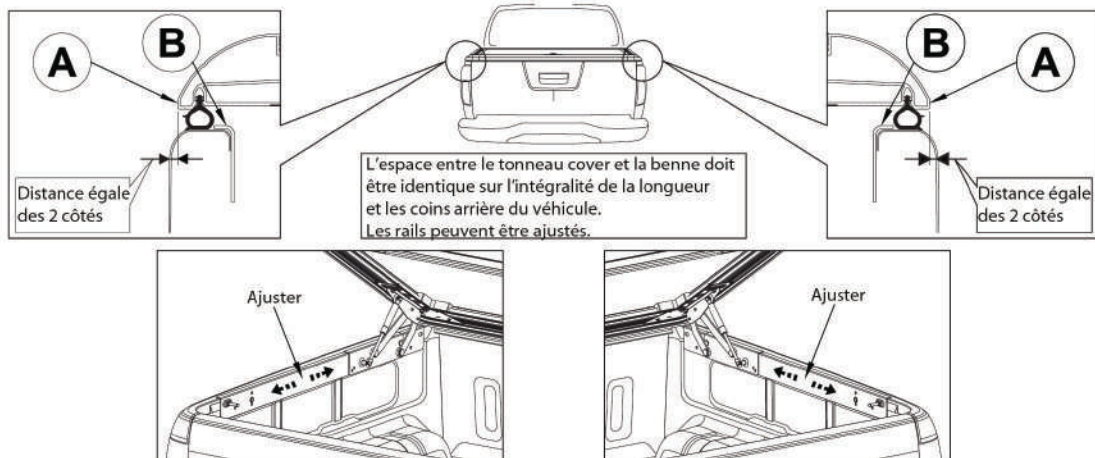

Une fois le montage terminé, nettoyez la benne de tous les débris et emballages.
Gardez cette notice de montage pour une utilisation future.

⚠ ATTENTION !

- Ne jamais enfermer dans la benne des personnes ou des animaux.
- Ne pas transporter des solvants ou produits chimiques ouverts.
- Ne pas marcher sur le tonneau cover ou y placer des objets lourds.
- Ne pas soulever le cover avec un chargement.
- Ne pas rouler avec le tonneau cover ouvert.
- Eviter tout contact d'huile, solvants ou produits chimiques avec le cover.
- Nettoyer le cover avec un détergent doux et de l'eau.

Kit de montage	Article	Revision	Date	Page
K408	Tonneau cover UpStone	1	26.02.2018	7 sur 7